



Cast Steel Check Valve



Swing check Valve
Cast Steel
Bolted Bonnet
Flanged end
Class 150, 300 & 600
2"-12"

Applications

- Refineries, Power stations, Process & General Industry
- For water, steam, gas, oil and other non-aggressive media
- Further applications on request

Operating data

- Pressure range up to 104 bar (1480 PSI)
- Temperature range up to +593°C/1100°F
- Pressure-temperature ratings as per ASME B 16.34 Special class

Materials

ANSI Standard Class (as per ASME B 16.34)

- #150/300/600 - A 216 WCB from 0°C to 425°C
- #600 - A 217 WC6 from 0°C to 593°C
- #150/300 - 351 CF8 from 0°C to 537°C
- ASME Special class on request.

Design

- As per BS 1868
- Pressure, Temperature rating as per ASME B 16.34
- Stellite hard-faced Seats

Variants on Request

- Trim 8, Trim 5 for #150/300 valves
- Trim 5 for #600 WCB valves
- Trim 8 for #600 WC6 valves
- Other material of construction on request
- Drain Plug

Remarks

Forged Valves leaflet no.	: 0500.10/01 - 18 G3
Pressure Seal Gate Valve leaflet no.	: 0501.10/01 - 18 G3
Pressure Seal Globe Valve leaflet no.	: 0502.10/01 - 18 G3
Pressure Seal Check Valve leaflet no.	: 0503.10/01 - 18 G3
Cast Steel Gate Valve leaflet no.	: 0501.11/01 - 18 G3
Cast Steel Globe Valve leaflet no.	: 0502.11/01 - 18 G3
Operating instructions no.	: 0500.80/01 - 18 G3

When ordering spares indicate valve serial number

On all enquiries/orders please specify

- | | |
|-----------------------------|------------------------------------|
| 1. Type | 8. Flow Medium |
| 2. ANSI Pressure class | 9. Type of end connection |
| 3. Size | 10. Pipe schedule |
| 4. Design pressure | 11. Variants |
| 5. Operating pressure | 12. Leaflet number |
| 6. Differential pressure | 13. Valve data sheet if applicable |
| 7. Material of construction | |





Product Features to our Customers Benefit

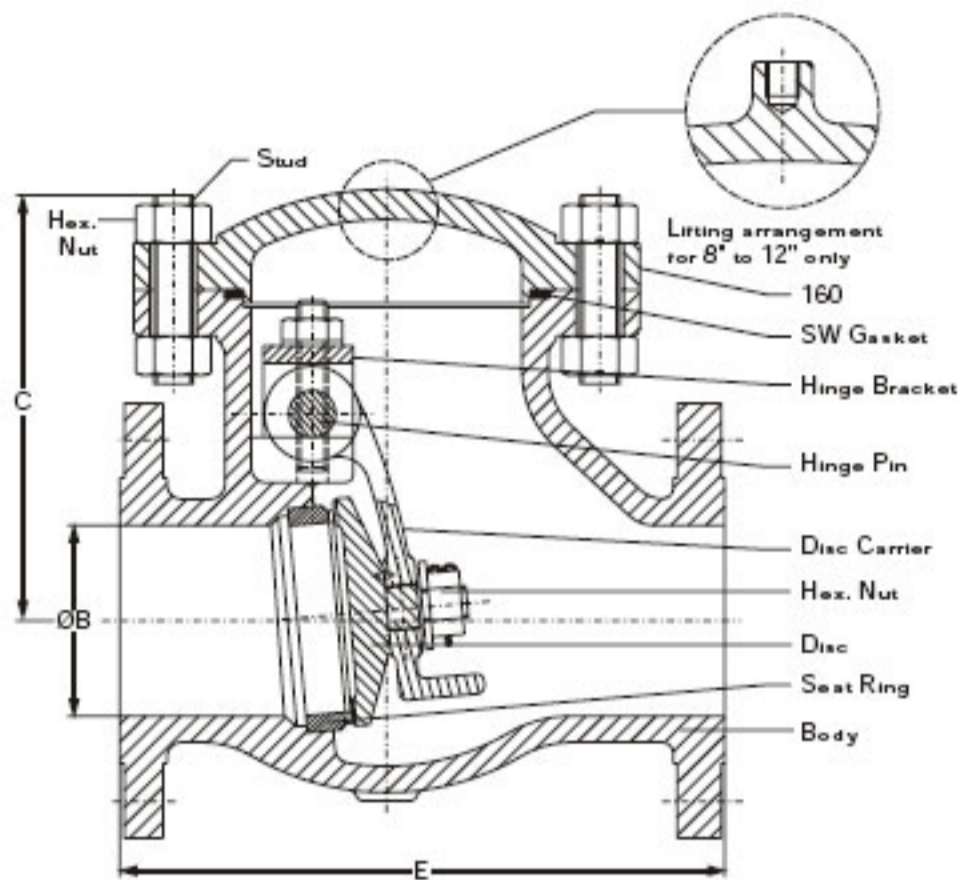

- Inside hinge pin mounted design eliminates leakage path to atmosphere
- Self aligning free floating and non rotating disc
- Designed to open at low differential pressures

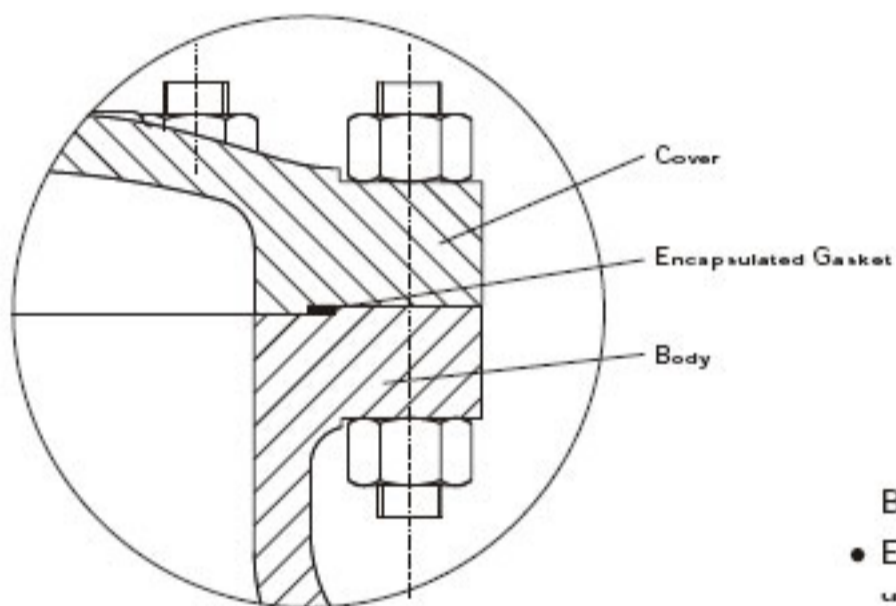

Body Cover joint

- Encapsulated Gasket ensures leak-proof and unwinding of SS spiral metal

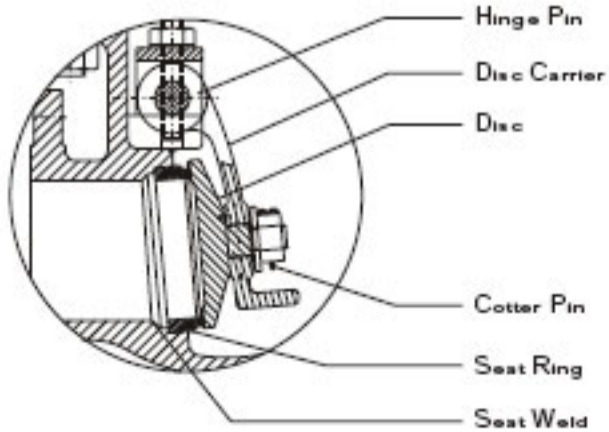

Disc Design

- Self aligning disc ensures perfect seating
- Designed to open at low differential pressure

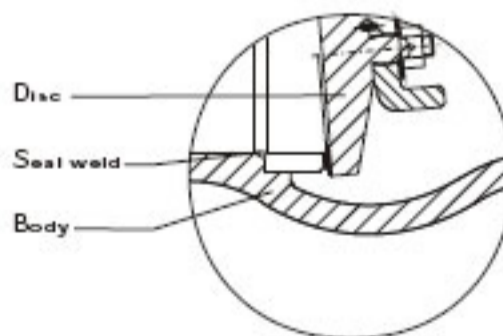

Flow Seat

- Stellite seat
- Seat rings - seal welded to body
- Lapped Seat & Disc faces for leak tightness
- Streamlined flow path ensures minimum pressure drop

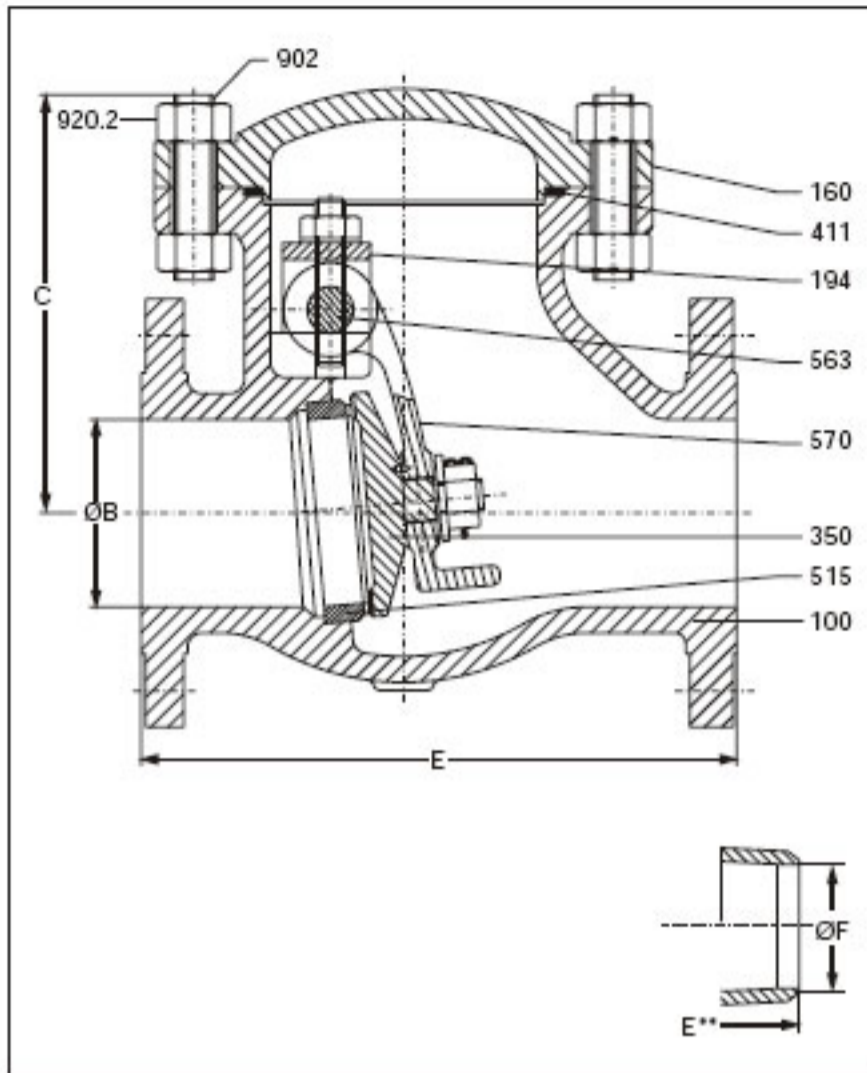

Dimensions

Class 150	2"	3"	4"	6"	8"	10"	12"	
E	Inch	8.0	9.5	11.5	14.0	19.5	24.5	27.5
	mm	203.0	241.0	292.0	356.0	495.0	622.0	699.0
ØB	Inch	2.0	3.0	4.0	6.0	8.0	10.0	12.0
	mm	51.0	76.0	102.0	152.0	203.0	254.0	305.0
C	Inch	5.3	7.0	8.0	10.0	12.0	15.0	16.0
	mm	135.0	175.0	200.0	255.0	307.0	380.0	407.0
E**	Inch	8.0	9.5	11.5	14.0	19.5	24.5	27.5
	mm	203.0	241.0	292.0	356.0	495.0	622.0	699.0
ØF	Inch	2.1	3.1	4.0	6.1	8.0	10.0	11.9
	mm	53.0	78.0	102.0	154.0	203.0	255.0	303.0

* Schedule 40 for class 150. Alternate schedule on request.
E** - End to End or BW end valves.

Class 300	2"	3"	4"	6"	8"	10"	12"	
E	Inch	10.5	12.5	14.0	17.5	21.0	24.5	28.0
	mm	267.0	318.0	356.0	445.0	533.0	622.0	711.0
ØB	Inch	2.0	3.0	4.0	6.0	8.0	10.0	12.0
	mm	51.0	76.0	102.0	152.0	203.0	254.0	305.0
C	Inch	5.6	7.0	8.0	10.0	12.6	14.8	16.7
	mm	142.0	175.0	200.0	250.0	320.0	375.0	425.0
E**	Inch	10.5	12.5	14.0	17.5	21.0	24.5	28.0
	mm	267.0	318.0	356.0	445.0	533.0	622.0	711.0
ØF	Inch	2.1	3.1	4.0	6.1	8.0	10.0	11.9
	mm	53.0	78.0	102.0	154.0	203.0	255.0	303.0

* Schedule 40 for class 300. Alternate schedule on request.

Design Specifications

- General valve design : BS 1868
- Pressure, temperature rating : ASME B 16.34
Standard class
- Flanged end design : ASME B 16.5
- End to end dimension : ASME B 16.10
- Testing standard : API 598

Class 600	2"	3"	4"	6"	8"	10"	12"	
E	Inch	11.5	14.0	17.0	22.0	26.0	31.0	33.0
	mm	292.0	356.0	432.0	559.0	660.0	787.0	838.0
ØB	Inch	2.0	3.0	4.0	6.0	8.0	9.8	11.7
	mm	51.0	76.0	102.0	152.0	200.0	248.0	298.0
C	Inch	6.9	8.1	9.8	10.8	14.5	16.3	20.4
	mm	175.0	206.0	250.0	272.0	370.0	415.0	518.0
E**	Inch	11.5	14.0	17.0	22.0	26.0	31.0	33.0
	mm	292.0	356.0	432.0	559.0	660.0	787.0	838.0
ØF	Inch	1.9	2.9	3.8	5.8	7.6	9.6	11.4
	mm	49.0	74.0	97.0	146.5	194.0	243.0	289.0

* Schedule 80 for class 600. Alternate schedule on request.
E** - End to End or BW end valves.

Materials

Part No.	Description	Material			
100	Body	A 216-WCB	A 217-WC6	A 351-CF8	A 351-CF8M
160	Cover	A 216-WCB	A 217-WC6	A 351-CF8	A 351-CF8M
194	Hinge Bracket	A 216-WCB	IS 2062	A 182-F304	A 182-F304
350	Disc	A 217-CA15	A 217-WC6 + ST6	A 351-CF8	A 351-CF8M
		A 216-WCB+13%Cr			
411	SW Gasket	SS 316 + GRPH	SS 316 + GRPH	SS 316 + GRPH	SS 316 + GRPH
515	Seat Ring	A 216-WCB + ST6	A 182-F11 + ST6	A 351-CF8	A 351-CF8M
563	Hinge Pin	A 276-410 (H)	A 276-410 (H)	A 276-304	A 276-304
570	Disc Carrier	A 216-WCB	A 217 - WC6	A 351-CF8	A 351 - CF8M
902	Stud	A 193-B7	A 193-B16	A 193-B8	A 193 - B8M
920.1	Hex. Nut	A 194-2H	A 194-4	A 193-B8	A 194-8M
920.2	Hex. Nut	SS (18-8)	SS (18-8)	SS (18-8)	A 194-8M

Note : Subject to change without notice on account of continuous improvement.



Test Specifications

Test / Test pressure	#150		#300		#600		Testing medium
	kg/cm ²	PSI	kg/cm ²	PSI	kg/cm ²	PSI	
Shell	30	455	77	1138	157	2233	Kerosene / Water
Seat leak	22	327	57	825	115	1636	

Material : A 216 WCB Table A : Standard Class

Temperature		#150		#300		#600	
°F	°C	PSI	kg/cm ²	PSI	kg/cm ²	PSI	kg/cm ²
-20 to 100	-17 to 38	285	20.0	740	52.0	1480	104.1
200	93.3	260	18.3	675	47.5	1350	94.9
300	148.9	230	16.2	655	46.1	1315	92.5
400	204.4	200	14.1	635	44.6	1270	89.3
500	260.0	170	12.0	600	42.2	1200	84.4
600	315.6	140	9.8	550	38.7	1095	77.0
650	343.3	125	8.8	535	37.6	1075	75.6
700	371.1	110	7.7	535	37.6	1065	74.9
750	398.9	95	6.7	505	35.5	1010	71.0
800	426.7	80	5.6	410	28.8	825	58.0
850	454.4	65	4.6	270	19.0	535	37.6
900	482.2	50	3.5	170	12.0	345	24.3
950	510.0	35	2.5	105	7.4	205	14.4
1000	537.8	20	1.4	50	3.5	105	7.4

Material : A 217 WC6 Table B : Standard Class

Temperature		#150		#300		#600	
°F	°C	PSI	kg/cm ²	PSI	kg/cm ²	PSI	kg/cm ²
-20 to 100	-17 to 38	290	20.4	750	52.7	1500	105.5
200	93.3	260	18.3	750	52.7	1500	105.5
300	148.9	230	16.2	720	50.6	1445	101.6
400	204.4	200	14.1	695	48.9	1385	97.4
500	260.0	170	12.0	665	46.8	1330	93.5
600	315.6	140	9.8	605	42.5	1210	85.1
650	343.3	125	8.8	590	41.5	1175	82.6
700	371.1	110	7.7	570	40.1	1135	79.8
750	398.9	95	6.7	530	37.3	1065	74.9
800	426.7	80	5.6	510	35.9	1015	71.4
850	454.4	65	4.6	485	34.1	975	68.6
900	482.2	50	3.5	450	31.6	900	63.3
950	510.0	35	2.5	320	22.5	640	45.0
1000	537.8	20	1.4	215	15.1	430	30.2
1050	565.6	20	1.4	145	10.2	290	20.4
1100	593.3	20	1.4	95	6.7	190	13.4
1150	621.1	20	1.4	60	4.2	125	8.8
1200	648.9	15	1.1	40	2.8	75	5.3

Material : A 351 CF8 Table C : Standard Class

Temperature		#150		#300		#600	
°F	°C	PSI	kg/cm ²	PSI	kg/cm ²	PSI	kg/cm ²
-20 to 100	-17 to 38	275	19.3	720	50.6	1440	101.2
200	93.3	235	16.5	600	42.2	1200	84.4
300	148.9	205	14.4	540	38.0	1080	75.9
400	204.4	190	13.4	495	34.8	995	70.0
500	260.0	170	12.0	465	32.7	930	65.4
600	315.6	140	9.8	435	30.6	875	61.5
650	343.3	125	8.8	430	30.2	860	60.5
700	371.1	110	7.7	425	29.9	850	59.8
750	398.9	95	6.7	415	29.2	830	58.4
800	426.7	80	5.6	405	28.5	805	56.6
850	454.4	65	4.6	395	27.8	790	55.5
900	482.2	50	3.5	390	27.4	780	54.8
950	510.0	35	2.5	380	26.7	765	53.8
1000	537.8	20	1.4	320	22.5	640	45.0
1050	565.6	20	1.4			615	43.2
1100	593.3	20	1.4	255	17.9	515	36.2
1150	621.1	20	1.4	200	14.1	400	28.1
1200	648.9	20	1.4	155	10.9	310	21.8
1250	676.7	20	1.4	115	8.1	225	15.8
1300	704.4	20	1.4	85	6.0	170	12.0
1350	732.2	20	1.4	60	4.2	125	8.8
1400	760.0	20	1.4	50	3.5	95	6.7
1450	787.8	15	1.1	35	2.5	70	4.9
1500	815.6	10	0.7	25	1.8	55	3.9

Material : A 351 CF8M Table D : Standard Class

Temperature		#150		#300		#600	
°F	°C	PSI	kg/cm ²	PSI	kg/cm ²	PSI	kg/cm ²
-20 to 100	-17 to 38	275	19.3	720	50.6	1440	101.2
200	93.3	235	16.5	620	43.6	1240	87.2
300	148.9	215	15.1	560	39.4	1120	78.7
400	204.4	190	13.4	515	36.2	1025	72.1
500	260.0	170	12.0	480	33.7	955	67.1
600	315.6	140	9.8	450	31.6	900	63.3
650	343.3	125	8.8	445	31.3	890	62.6
700	371.1	110	7.7	430	30.2	870	61.2
750	398.9	95	6.7	425	29.9	855	60.1
800	426.7	80	5.6	420	29.5	845	59.4
850	454.4	65	4.6	420	29.5	835	58.7
900	482.2	50	3.5	415	29.2	830	58.4
950	510.0	35	2.5	385	27.1	775	54.5
1000	537.8	20	1.4	350	24.6	700	49.2
1050	565.6	20	1.4	345	24.3	685	48.2
1100	593.3	20	1.4	305	21.4	610	42.9
1150	621.1	20	1.4	235	16.5	475	33.4
1200	648.9	20	1.4	185	13.0	370	26.0
1250	676.7	20	1.4	145	10.2	295	20.7
1300	704.4	20	1.4	115	8.1	235	16.5
1350	732.2	20	1.4	95	6.7	190	13.4
1400	760.0	20	1.4	75	5.3	150	10.5
1450	787.8	20	1.4	60	4.2	115	8.1
1500	815.6	20	1.4	40	2.8	85	6.0