



The Figure 990 butterfly valve has a split, wafer type body, features a one piece disc stem and field replaceable seat.

The range of available materials makes these valves suitable for a wide variety of applications.

Features

- Factory testing of every valve at full rating ensures 100% bubble-tight shut-off.
- Standardised actuator flange for easy operator interchangeability and mount direct to United Range of actuators.
- One-piece wafer-thin disc-stem provides high strength and absolutely positive disc control and gives the very minimum obstruction to flow. Its crevice free surface makes it ideal for hygienic duty.
- Primary seal formed by the seat/shaft/hub contact exceeds the pressure rating of the valve. Body is totally isolated from the flowing medium.
- Secondary shaft seal is suitable for pressure and vacuum is self adjusting.
- Patented dove-tail seat requires no bonding. Makes seat replacement simple and fast. Extra heavy edge section resists tearing.
- Hub seal is provided by preloaded contact between flatted seat surface and rounded polished disc-hub area for positive sealing at all disc positions.
- Moulded-in O-ring provides positive flange sealing and eliminates the need for gaskets.
- Heavy duty top bushing absorbs side thrust loads. Self-adjusting sealing for both directions is also suitable for vacuum.



General application

The figure 990-102/003 is the ideal valve for use in the food and beverage industries. The figure 990-007 is teflon lined for use in semi-aggressive chemical industries. Max pressure 7 bar. The figure 990-002 is rubber lined for use in the process industries. Max pressure 7 bar.

Technical data

Pressure (bar)	: 10
Temperature (°C)	: -10 to +150
Sizes (mm)	: 25-300
Flange accommodation	: PN 10/16 ANSI 150 BST'E'

Warning !
Not for use on unstable gasses.
Not for end of line use.



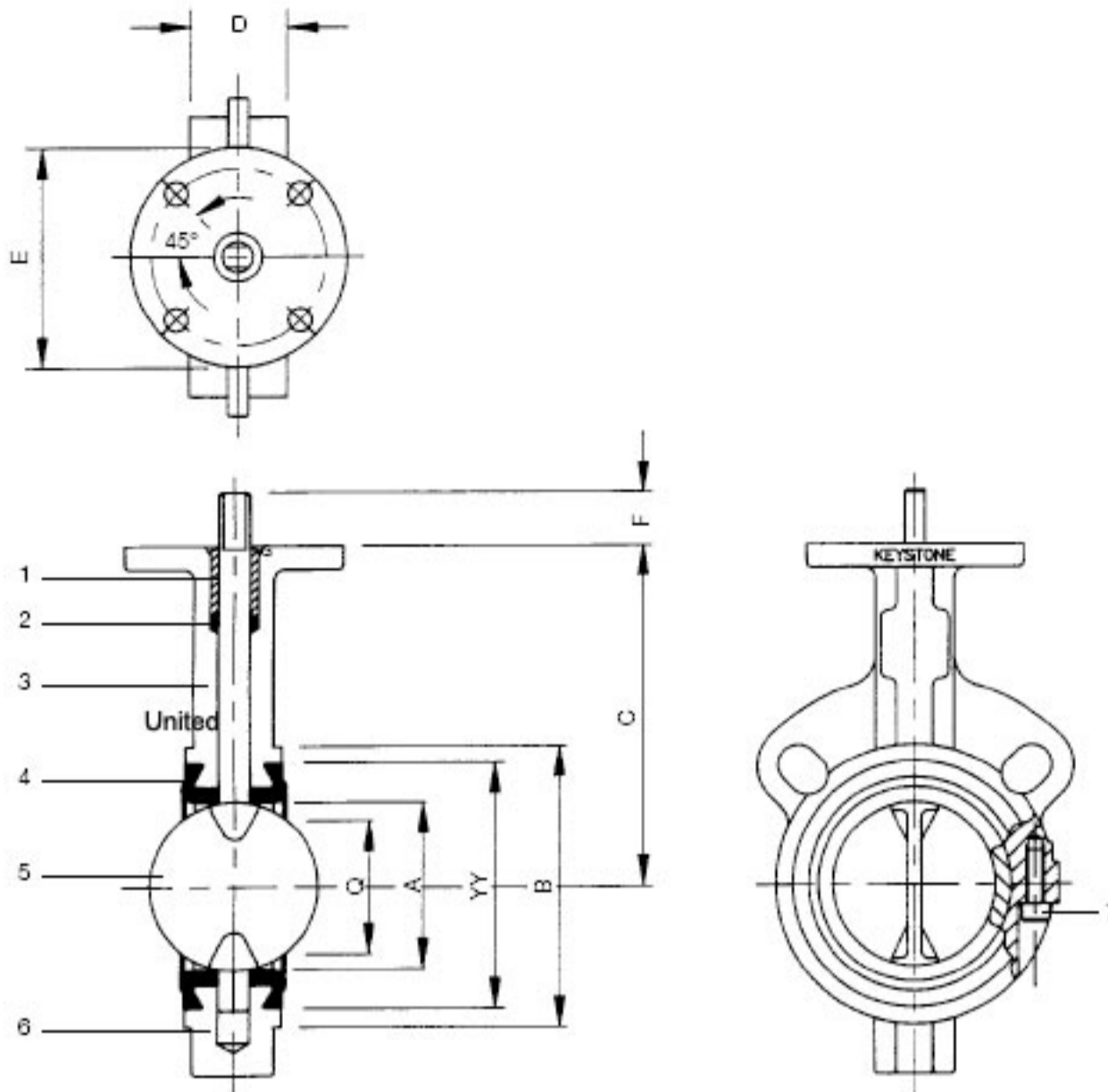

Part name

1. Bushing
2. Shaft seal
3. Upper body
4. Seat
5. Disc-stem
6. Lower body
7. Body screws

Valve dimensions in mm

Size	A	B	C	D	E	F	YY	Q	Mass (kg)
25	30	62	78	29	57	19	50	15	0.70
40	44	82	95	30	57	19	67	35	1.10
50	51	109	140	41	102	32	87	33	2.70
65	64	129	152	44	102	32	98	48	3.75
80	76	144	180	44	102	32	114	64	4.00
100	102	164	178	51	102	32	146	90	5.50
125	127	194	190	54	102	32	168	117	7.20
150	146	220	203	54	102	32	197	138	8.50
200	197	275	241	64	152	32	254	188	15.00
250	248	330	273	64	152	32	305	241	20.00
300	296	377	312	76	152	51	353	290	31.00



Actuator selection

Actuator type	Figure	Remark
Handle	F401	Handlever
Gear	F422	-
Pneumatic	F790	-
Gear & pneumatic	F453/790	Declutchable gearunit provides manual override for the Keystone pneumatic actuator.
Electric	F777	

Notes

1. Valve size shown is the 100 mm; other sizes show different configurations. For information see separate data sheets.
2. Q is the disc chordal dimension at face of valve for disc clearance into pipe fitting or equipment.





Note

1. Rated Kv = the volume of water in m³/hr that will pass through a given valve opening at a pressure drop of 1 bar.

K_v values

disc opening \ size in mm	25	40	50	65	80	100	125	150	200	250	300
10°	0,4	0,9	1,7	2,6	3,4	5	9	15	21	33	49
20°	1,7	4,3	7	10	14	25	38	52	95	155	220
30°	4,3	9,5	16	22	33	54	86	120	220	340	510
40°	8,9	16	26	38	57	95	160	220	380	610	880
50°	11	26	43	60	95	150	240	340	590	950	1480
60°	17	40	69	95	150	240	390	550	950	1550	2320
70°	29	66	110	160	240	400	640	950	1550	2580	3780
80°	46	103	170	250	370	620	950	1380	2410	3980	5850
90°	52	120	320	430	590	960	1510	2000	3550	5900	8480
90° *	52	120	320	430	590	960	1510	2000	3550	5900	8480

* Rubber covered disc

Maximum allowable shaft torques in Nm

shaft mat. \ size in mm	25	40	50	65	80	100	125	150	200	250	300
SS	20	20	60	60	60	100	180	180	290	725	725

Notes

1. **Application I :**
Water, seawater, lubricating types of hydrocarbons. Temp.: 0-80°C;
Valve opens at least once a month.
- Application II :**
All other liquid applications and lubricating gasses.
- Application III :**
Non lubricating and dry media.
2. The charted maximum sizing operating torque is the sum of all friction and resistance for opening and closing of the disc against the indicated pressure differential.
3. The effect of dynamic torque is not considered in tabulation.
4. In sizing operators it is not necessary to include safety-factors.

Sizing torques in Nm

ΔP in bar \ size in mm	25	40	50	65	80	100	125	150	200	250	300
Application I											
3,5	6	10	20	25	30	45	62	89	150	230	330
7	7	11	21	26	32	48	68	100	180	270	380
10	8	12	23	27	35	52	74	110	200	300	440
Application II											
3,5	8	12	27	32	39	59	81	120	200	300	420
7	9	13	28	33	42	62	87	130	220	330	470
10	10	14	29	35	44	66	92	140	240	370	530
Application III											
3,5	10	14	32	38	47	71	97	144	240	360	504
7	11	16	34	40	50	74	104	156	264	396	564
10	12	17	36	42	53	79	110	168	288	444	636

Notes

1. Dynamic operating torque formula:
 $T_D = F_T \times \Delta P$

 T_D = Dynamic torque (Nm)
 ΔP = Pressure drop across disc air desired disc-opening (bar)
 F_T = Dynamic torque factor (see table)
2. The dynamic torque includes all frictional resistances.
3. The dynamic torque is tending to close the disc.
4. The charted maximum allowable torques are only applicable for standard type valves.

Dynamic torque factors F_T for metric units

disc opening \ size in mm	25	40	50	65	80	100	125	150	200	250	300
10°	0,08	0,2	0,5	0,9	1,2	2,7	4,3	6,1	13	28	39
20°	0,10	0,2	0,7	1,0	1,5	3,4	5,9	8,7	20	40	61
30°	0,11	0,3	0,8	1,3	2,1	4,8	8,4	13	30	61	95
40°	0,15	0,5	1,0	1,5	3,0	6,4	12	20	47	94	153
50°	0,20	0,7	1,5	2,6	4,3	10	19	30	71	141	230
60°	0,25	0,8	2,1	3,9	6,4	15	29	48	112	220	380
70°	0,41	1,3	3,1	5,9	10	24	45	76	176	350	610
80°	0,57	1,8	4,4	8,5	14	34	65	112	260	520	890



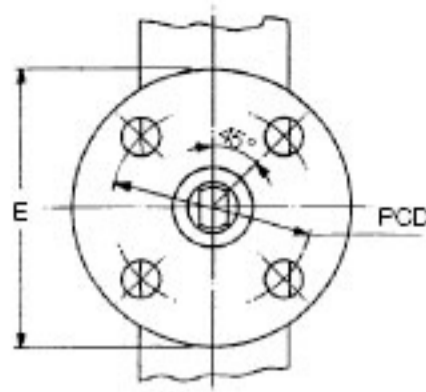

sizes 25-200 mm

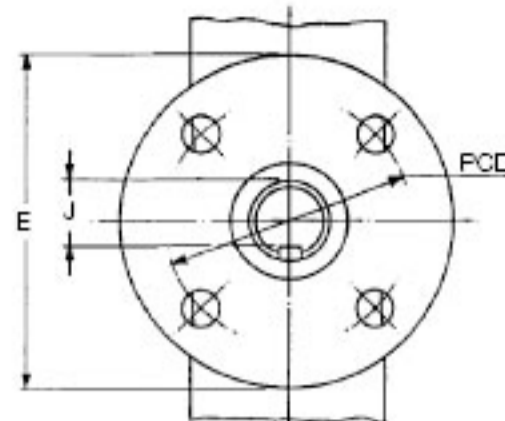

sizes 250-500 mm

Actuator flange dimensions in mm

Size	Shaft dimensions					Actuator flange dimensions				
	F	G	K	J	keysize width x height	E	P	PCD	hole ø	no. of holes
25	19	9,53	6,35	-	-	57	8	44,5	6,3	4
40	19	9,53	6,35	-	-	57	8	44,5	6,3	4
50	32	14,28	9,5	-	-	102	13	82,5	11,1	4
65	32	14,28	9,5	-	-	102	13	82,5	11,1	4
80	32	14,28	9,5	-	-	102	13	82,5	11,1	4
100	32	15,88	11,10	-	-	102	13	82,5	11,1	4
125	32	19,05	12,70	-	-	102	13	82,5	11,1	4
150	32	19,05	12,70	-	-	102	13	82,5	11,1	4
200	32	22,20	15,88	-	-	152	16	127,0	14,3	4
250	32	28,58	-	25,40	6,35 x 6,35	152	16	127,0	14,3	4
300	51	28,58	-	25,40	6,35 x 6,35	152	16	127,0	14,3	4
350	51	34,93	-	30,50	7,94 x 7,94	152	16	127,0	14,3	4
400	51	41,28	-	35,98	9,53 x 9,53	152	16	127,0	14,3	4
450	57	42,85	-	42,85	12,70 x 9,53	203	19	165,1	20,6	4
500	57	42,85	-	42,85	12,70 x 9,53	203	19	165,1	20,6	4

Material selection

Body	Disc	Shaft	Seat	Trim no.	Sizes(mm)
Cast Iron	Stainless steel	Stainless steel	EPDM	New 102 CEE2	25-300
	Stainless steel	Stainless steel	BUNA-N	Old 106 CEE3	25-300
	Stainless steel Mirror polished	Stainless steel	EPDM	003 CPE2N	25-300
Cast Iron nylon coated	Stainless steel EPDM covered	Stainless steel	EPDM	002 C2E2N	50-300
	Stainless steel	Stainless steel	Teflon/EPDM	005 CEE4N	50-300
	Stainless steel Teflon covered	Stainless steel	Teflon/EPDM	007 C4E4N	50-300

Material specification

Part name	Material	British Standard	DIN Standard
Body	Cast Iron	BS EN 1561: 1997 EN-GJL-250	DIN 1691 (GG-25)
Bodyscrews	Stainless steel		DIN 17006 (X-5 CrNi 18 9) or (X-5 CrNi 19 11)
Disc-stem	Stainless steel	BS 970 Part 4 316S16	DIN 17440 (X-5 CrNiMo 18 12)
	EPDM covered steel		DIN 1.4462 (X2 CrNiMo N 22 5)
	shaft	BSC Stainless Hysist 22/5	
	insert	BS 3601:74 (Grade 360)	DIN 1.0306 (St-35)
Teflon covered steel	shaft	BSC Stainless Hysist 22/5	DIN 1.4462 (X2 CrNiMo N 22 5)
	shaft	BSC Stainless Hysist 22/5	
	insert	BS 3601:74 (Grade 360)	DIN 1.0306 (St-35)
Seat	EPDM Teflon lined EPDM		
Packing	EPDM		
Bushing			

